

PZS3 SERIES ACCELEROMETER

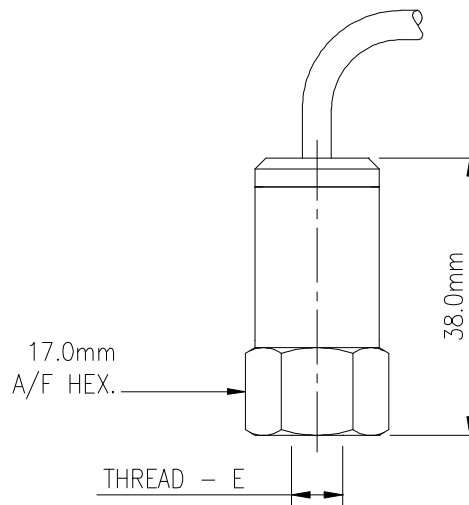

- SINGLE POINT MOUNT, TOP EXIT, EASY INSTALLATION
- LOW COST HEAVY DUTY PROTECTION
- DUAL CASE, LOW NOISE
- STAINLESS STEEL HERMETICALLY SEALED OUTER CASE
- FREQUENCY RANGE 0.4Hz TO 11KHz
- INTERNALLY SHIELDED
- ELECTRICAL AND THERMAL ISOLATION
- SHEAR MODE OPERATION

The PZS3 accelerometer is intended to satisfy the general specification requirements for a low cost vibration transducer for use especially in multi-point harsh environment industrial vibration monitoring applications.

The two-wire current-loop operating principle permits very long interconnecting cables to be used where necessary and at minimum expense since standard screened pair (or multi-pair) cables may be used.

The piezo-electric shear mode sensor and amplifier are contained within an inner metal enclosure, which is electrically and thermally insulated from the outer stainless steel body. The arrangement prevents earth loops and eliminates electrical interference, and minimises thermal shocks and base strain. The inner enclosure is connected to the 0V of the two wire system and is therefore an effective electrical screen. External connections are made via the top exit integral cable.

PZS3 ACCELEROMETER

SPECIFICATION

Operating Voltage/current	18 to 28 volts D. C. constant current source of 2 to 10mA
Output signal	100mV/g
Bias Voltage	12Vdc \pm 20%
Dynamic Range	Up to 70g peak (at 24Vdc input)
Frequency Range	0.4Hz to 11KHz (better than 3dB) (standard)
Transverse sensitivity	Less than 5%
Amplitude linearity	\pm 1% or better
Temperature sensitivity	Less than 8% up to 140°C
Residual electrical noise	Less than 0.2mg (2.5Hz to 11KHz)
Signal transmission	Two-wire system, 500Vac electrical isolation from body
Weight.....	95 gms (nominal)

Environmental

Acceleration limit:	Vibration	200g pk at 120Hz for 10 mins
	Shock	500g half sine
Temperature:	Operation	-30°C to +140°C
	Survival.....	-55°C to +160°C
		NB. Certain types of connector or cables may limit the temperature performance of the transducer, see IS. Sheet for details.
Protection (BS.EN60529).....		Sealed to IP.66 / IP.67

ORDERING INFORMATION

PZS3 -

A

B	
---	--

C	
---	--

D

E

F

A Electrical Configuration

2

 - 2 wire ICP device

B Connection Method

- | |
|---|
| 6 |
|---|

A

 Integral Cable (80°C) Unarmoured
- | |
|---|
| 6 |
|---|

B

 Integral Cable (80°C) Armoured
- | |
|---|
| 6 |
|---|

D

 Integral Cable (140°C) Armoured
- | |
|---|
| 8 |
|---|

E

 Integral Connector, 2 pin, circular, threaded
- | |
|---|
| 8 |
|---|

F

 Integral Connector, BNC

C Cable length (Specify in whole metres)

0	2
---	---

 e.g. = 2 metres (max 25 metres)

D Output & Frequency band (3dB point)

- | |
|---|
| 1 |
|---|

 100mV/g \pm 10% (0.4Hz - 11KHz)
- | |
|---|
| 2 |
|---|

 100mV/g \pm 5% (0.4Hz - 11KHz)

E Mounting Thread (Female)

- | |
|---|
| 1 |
|---|

 - ¼" UNF
- | |
|---|
| 3 |
|---|

 - M8
- | |
|---|
| 4 |
|---|

 - Quick Release

F Hazardous Area Approval

0

 - Non Intrinsic