

# HI Series LVDT

( Displacement Transducer)



- Heavy industrial.
- Connector or integral cable.
- Up to 180°C operation.

The HI heavy industrial LVDT displacement transducer consists of a standard linear variable differential transformer housed within a robust stainless steel body. The concentric tube of the telescopic assembly are guided by means of a linear bearing and are retained by rigid end stops within the body. The fixed and moving ends of the transducer are fitted with rod end bearings for mounting purposes.

The rugged and reliable construction of this series makes it particularly suited to heavy industrial applications and ‘uncomfortable’ environments. Of conventional LVDT principle these transducers are designed for use on low voltage AC supplies at frequencies between 50Hz and 5kHz.

The rod end bearings are screwed into the two body end sections and are fitted with lock nuts. The length of thread on one end bearing permits an adjustment of  $\pm 6\text{mm}$  ( $\pm 0.25$  inches) to provide a fine control of mechanical zero position.

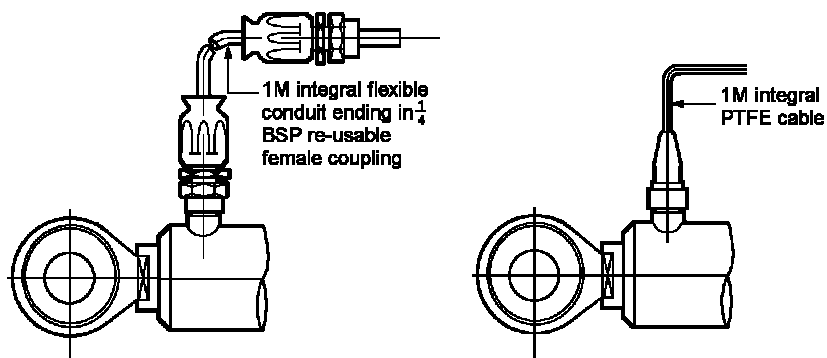
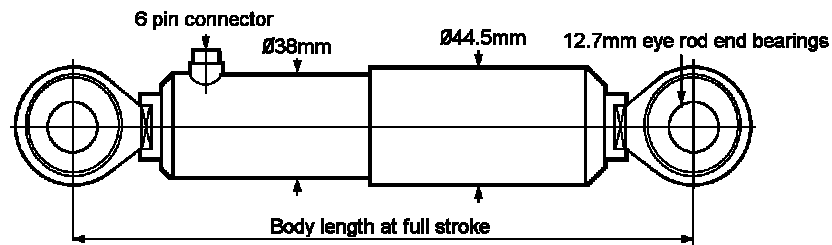

Note: other cable and conduit lengths available.

## Specifications

Input voltage .....	From less than 1V to 10V RMS
Input frequency.....	5Hz to 5kHz
Max. recommended primary current.....	20mA
Working temperature range.....	-40°C - +150°C (180°C integral cable)
Survival temperature range.....	-50°C to +150°C (180°C integral cable)
Linearity.....	Better than 0.5% full scale
Repeatability.....	Better than 0.02% reading
Body material.....	EN 58 (Non-magnetic stainless steel)
Core material.....	EN 56 (Magnetic stainless steel)
Calibration I/P signal.....	5V RMS @ 3kHz

<b>Transducer Type</b>	<b>HI25</b>	<b>HI50</b>	<b>HI100</b>	<b>HI150</b>
<b>Total Displacement range (mm)</b>	25	50	100	150
<b>Output at full range (mV/V at 3kHz)</b>	350	460	720	780
<b>Null Voltage (%FRO)</b>	0.6	0.4	1.2	1.6
<b>Primary impedance at 3 kHz</b>	540	200	550	550
<b>Primary resistance (Ohms)</b>	120	120	180	260
<b>Secondary Impedance</b>	240	200	350	560
<b>Secondary Resistance total (Ohms)</b>	160	190	340	470
<b>Zero phase frequency (kHz)</b>	2.4	3.8	3.75	4
<b>Weight excl. cable (GRMS)</b>	1.9	2.4	3	3.3
<b>Body length (mm)</b>	351	474	661	834

**Options:** Cable length PTFE over-sheath on flexible conduit.  
Integral connector, Integral cable

**DS1190-1**



**Sensonics Ltd,**  
Berkhamsted,  
Hert's, HP4 1EF,  
England  
Tel: +44(0) 1442 876 833.  
Fax: +44(0) 1442 876 477.