

PZS1 SERIES ACCELEROMETER

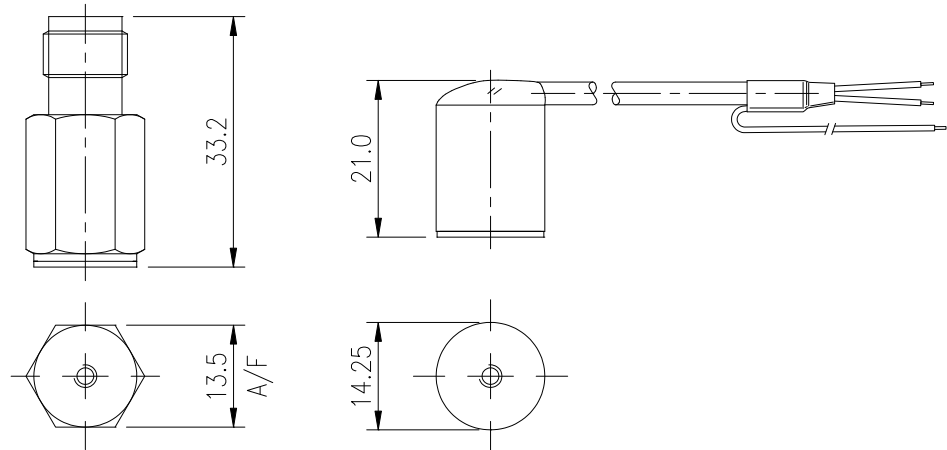

- **LOW COST GENERAL PURPOSE ACCELEROMETER**
- **EMBEDDED APPLICATIONS/MODAL ANALYSIS**
- **EASY INSTALLATION, THREAD OR ADHESIVE MOUNT**
- **SMALL BODY SIZE FOR EASE OF POSITIONING**
- **LIGHTWEIGHT, ONLY 16 GRAMS**
- **SINGLE CASE, LOW NOISE**
- **STAINLESS STEEL HERMETICALLY SEALED CASE**
- **FREQUENCY RANGE 0.4Hz TO 11kHz**
- **SHEAR MODE OPERATION**
- **AVAILABLE WITH INTEGRAL CONNECTOR**

The PZS1 accelerometer is Sensonics base model accelerometer for modal analysis and can also be used in OEM applications where the unit can be screwed, glued or embedded into machinery.

Being small and lightweight, it lends itself to being used where there simply isn't enough room to fit a standard industrial accelerometer and consequently has little effect on the vibrating surface itself.

The hermetically sealed version has the cable exiting radially from the top surface, however a PCB connection version is available with solder pads.

Because the PZS1 is a 'shear' mode accelerometer it is very tolerant of surface irregularities and offers a wide frequency response whilst maintaining good stability at varying ambient temperatures.

The two-wire current-loop operating principal permits very long interconnecting cables to be used where necessary and at minimum expense since standard screened pair (or multi-pair) cables may be used.

PZS1 ACCELEROMETER

SPECIFICATION

Operating Voltage/current	18 to 28 volts DC constant current source of 2 to 10mA
Output signal.....	100mV/g
Bias Voltage.....	12Vdc $\pm 20\%$
Dynamic Range.....	Up to 70g peak (at 24Vdc input)
Frequency Range	0.4Hz to 11KHz (better than 3dB) (standard)
Transverse sensitivity	Less than 5%
Amplitude linearity	$\pm 1\%$ or better
Temperature sensitivity	Less than 8% up to 120°C
Residual electrical noise	Less than 0.2mg (2.5Hz to 11KHz)
Signal transmission	Two-wire system,
Weight	16 gms (nominal, non-connectorised version)
Casing arrangement	Single case, non-isolated

Environmental

Acceleration limit:	Vibration	200g pk at 120Hz for 10 mins
	Shock	1000g peak
Temperature:	Operation	-30°C to +140°C
	Survival	-55°C to +150°C
		NB. Certain types of cable may limit the temperature performance of the transducer, see IS. Sheet for details.
Protection (BS.EN60529).....		Welded case to IP.65 base unit. Cable types hermetically sealed and bonded to IP.66.

ORDERING INFORMATION

PZS1 -

A		B		C		D		E		F	
---	--	---	--	---	--	---	--	---	--	---	--

A Electrical Configuration

2

 - 2 wire ICP device

B Connection Method

<table border="1" style="display: inline-table; vertical-align: middle;"><tr><td style="width: 20px; height: 20px; text-align: center;">0</td><td style="width: 20px; height: 20px; text-align: center;">0</td></tr></table>	0	0	Contact solder pads
0	0		
<table border="1" style="display: inline-table; vertical-align: middle;"><tr><td style="width: 20px; height: 20px; text-align: center;">6</td><td style="width: 20px; height: 20px; text-align: center;">A</td></tr></table>	6	A	Integral Cable PVC (80°C) Unarmoured
6	A		
<table border="1" style="display: inline-table; vertical-align: middle;"><tr><td style="width: 20px; height: 20px; text-align: center;">6</td><td style="width: 20px; height: 20px; text-align: center;">C</td></tr></table>	6	C	Integral Cable PVFD (140°C) Unarmoured
6	C		
<table border="1" style="display: inline-table; vertical-align: middle;"><tr><td style="width: 20px; height: 20px; text-align: center;">6</td><td style="width: 20px; height: 20px; text-align: center;">D</td></tr></table>	6	D	Integral TNC (threaded) connector
6	D		

C Cable length (Specify in whole metres)

0	2
---	---

 e.g. = 2 metres (max 25 metres)

D Output & Frequency band (3dB point)

<table border="1" style="display: inline-table; vertical-align: middle;"><tr><td style="width: 20px; height: 20px; text-align: center;">1</td></tr></table>	1	100mV/g $\pm 10\%$ (0.4Hz - 11KHz)
1		
<table border="1" style="display: inline-table; vertical-align: middle;"><tr><td style="width: 20px; height: 20px; text-align: center;">2</td></tr></table>	2	100mV/g $\pm 5\%$ (0.4Hz - 11KHz)
2		

E Female Mounting Thread

1

 - M3/Direct Bonding (Adhesive or Beeswax)

F Hazardous Area Approval

0

 - Non Intrinsic

If the option you require is not listed above, please check with our sales office regarding the availability.

Mtg. studs and magnet mounting bases available, See DS.1119

DS.1160-2



Sensonics Ltd,
 Berkhamsted,
 Herts, HP4 1EF,
 England
 Tel: +44 (0)1442 876833.
 Fax: +44 (0)1442 876477.